

Clamp Crane CB4-2 (for Tubular Piles)

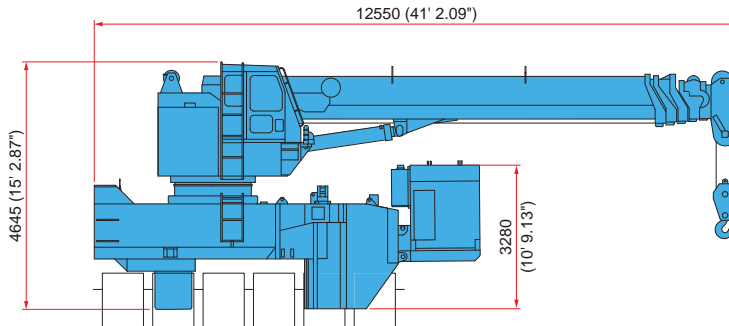
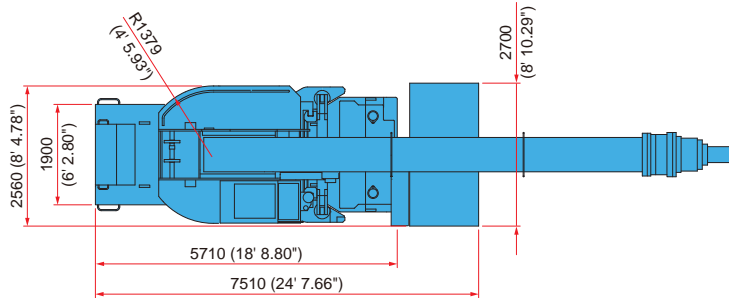

CB4-2	Metric Unit	US Standard
Applicable Reaction Piles	D812.8 - 1524 mm	D32.00 - 60.00 in
Lifting Capacity	20000 kg x 8.0 m	44092 lb x 26.24 ft
Max. Working Radius	34.0 m	111.54 ft
Rear-end Swing Radius	R1370 mm	53.93 in
Crane Operation	Manual	
Movement on Piles	Self-moving	
Self-moving Operation	Remote Control	
Power Source	Diesel Engine	
Rated Output	195 kW	261 HP
Mass	49900 kg	110010 lb

Specifications are subject to alteration without prior notice.